

# ANALIZADOR DE ENERGIA RIEL DIN ETHERNETPORT

SDE400E (K) , SDE430E-C (K) , SDE430E-R (K)

## 1. GENERAL

SDE430E-C mini DIN rail 3 phase power analyzer is designed special for renovation project of energy management (EMS). It has 3 external split core CTs (5~600A) or 3 Rogowski coils (200~6000A), so we don't need to dismantle bus to install it. By its DIN rail installation, it is very suitable to be used with breakers, contactors.

Besides electrical energies, it can measure all the parameters on the electrical networks, such as currents, voltages, active powers, reactive powers, apparent powers, frequency, power factors and 4 quadrant energies. It is designed as just 2 modules, so it can be installed in any so small space or to use it as multi channel 3 phase analyzer. Every SDE430E-C has a RJ45 interface to transfer its measuring data by Modbus-TCP to other master devices, such as PLC, data center computers.

SDE430E-C has good cost performance, as an intelligent unit and a digital electrical data collection unit, it has been widely used in many intelligent systems.

## 2. FUNCTIONS

- **Measuring:** 30 parameters on AC electrical network:
  - AL1, AL2, AL3(current senses), VL1, VL2, VL3, VL1-2, VL2-3, VL3-1, Fr,
  - PL1, PL2, PL3, PL,QL1, QL2, QL, SL1, SL2, SL3, SL, PF1, PF2, PF3, PF,
  - imp & exp kWh, L & C kvarh
- **Display:** With 8 digits LCD, display range 000000.00~99999999 kWh;
  - keep kWh value without power;
  - dot will move according to energy value to 8 integer digits;
- **Dimension:** 4 modules (72×89×74mm);
- **Current Input:**
  - SDE430E-C: split core CT (option 5A, 20A, 40A, 60A, 100A, 200A, 400A, 600A);
  - SDE430E-R: rogowski coil (option 200, 600A, 1kA, 2kA, 4kA, 6kA);
  - (5A split core CT is applied on the secondary cable of original 5A CT);
- **Line & Voltage Input:**
  - 3P4L (3x57.7/100V, 3x127/220V, 3x230V/400V,3x240/415V);
  - 3P3L (3x100V, 3x220V, 3x380V)
- **Power Supply:** Default axiliary power supply AC/DC85~265V;
  - Optional DC5V/12V/24V/48V
- **Communication:** With RJ45 interface by Modbus-TCP protocol;
- **Pulse:** kWh impulse output (comply DIN43864);
- **Relay ouput:** Optional 1 relay output as remote switch or as alarm;
- **Autodiagnosis:** for wiring error alarm, check error reason by alarm code;
- **Mounting:** 35mm standard DIN rail installation;
- **Software:** With free testing software, to easily read its data and set its parameters by computer;

### 3. FEATURES

Technical Feature		Parameters
Input	Wiring	1P2L, 3P3L, 3P4L
	Voltage	2x110V/220V, 3x57.7/100V, 3x127/220V, 3x230V/400V,3x240/415V 3x100V, 3x220V, 3x380V
		Rated 0.9 ~ 1.1Un; Max 0.7 ~ 1.2Un
		Consumption ≤5VA / line
	Current	SDE430E-C: 5A (to measure normal 5A CT), 20A, 40A, 60A, 100A, 200A, 400A, 600A (Split core CT) SDE430E-R: 200A, 600A, 1kA, 2kA, 4kA, 6kA(Rogowski Coil)
		Consumption ≤4VA / line
	Frequency	50 / 60Hz
	Accuracy	U,I,P 0.5%, kWh 1.0%
Thermal drift	<200ppm	
RJ45 TCP interface	Brand	10/100M
	Protocol	Modbus-TCP
	Def. Port	502
	Broadcasting	Broadcasting searching under the same network
Relay Ouput (Option K )	Mode	Dry Contact
	Capacity	Capcity: AC250/3A,DC24/5A
Energy Impulse		kWh impulse (open-collector)
		VCC<48V, Iz<50mA
		Constant: 10imp/kWh
Auxiliary power supply		AC/DC85-265V; Consumption < 5VA
Isolation		2kVAC/min ( input / output / power supply)
		input / housing and output / housing >50MΩ
Installation		Standard 35mm DIN rail
Standard		IEC 61557-12 Class 0.5
		IEC 62053-21 Class 1.0
Environment		Work Temperature: -20C ~ +55C
		Storage Temperature: -40C ~ +70C
		Relative humidity: 5% ~ 95% (no condensation)
		Altitude: < 2500m
Others		Dimension: 72×89×74 (mm)
		Weight: 345g (net without CT)

## 4. DIMENSION

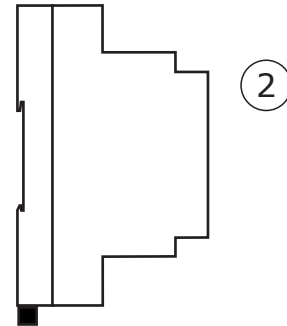
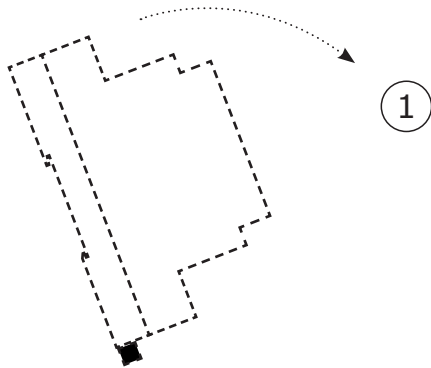
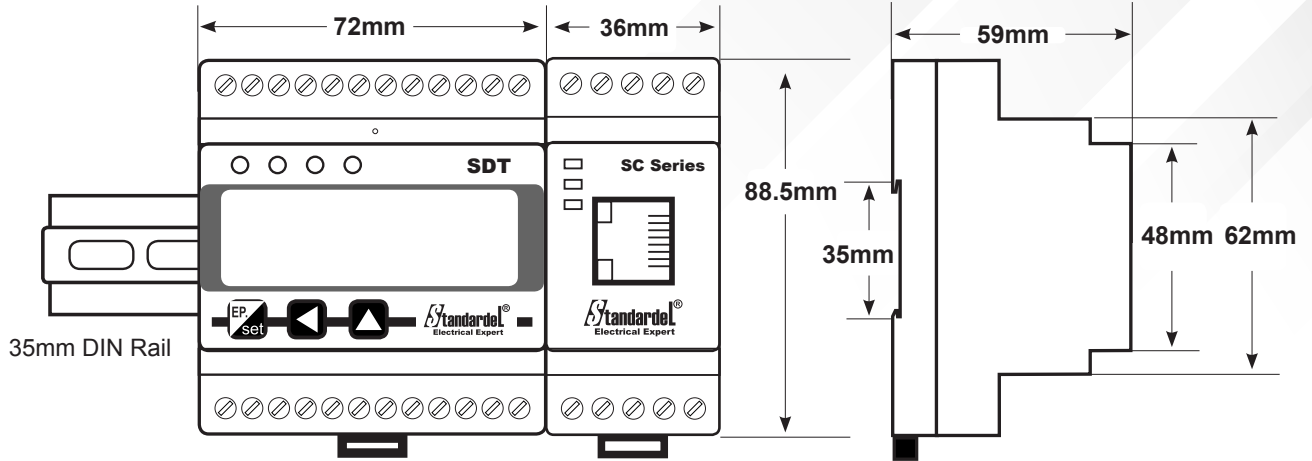

Impulse of kWh

Impulse of kVarh

LCD displayer

Buttons

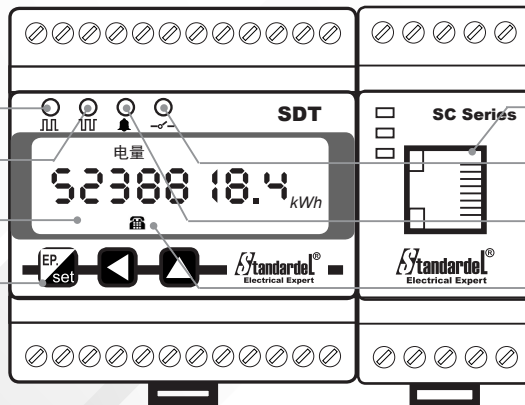

RJ45 Interface

Relay State (Option)

Alarm of Wiring Error

Communication

## 5. WIRING

### 5.1 SDE400E ( FOR NORMAL 5A (1A) CT. )

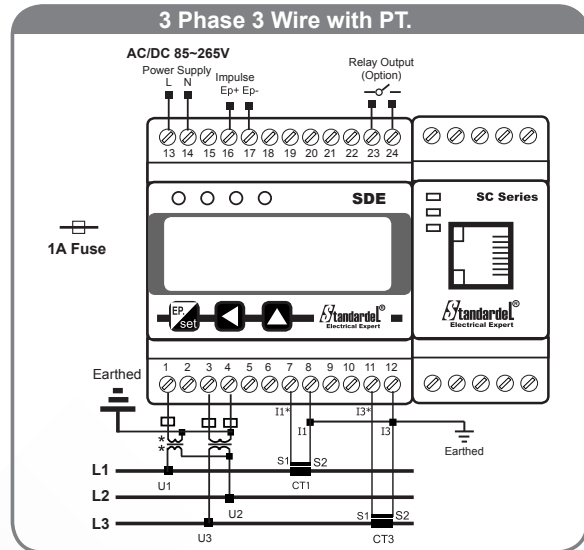
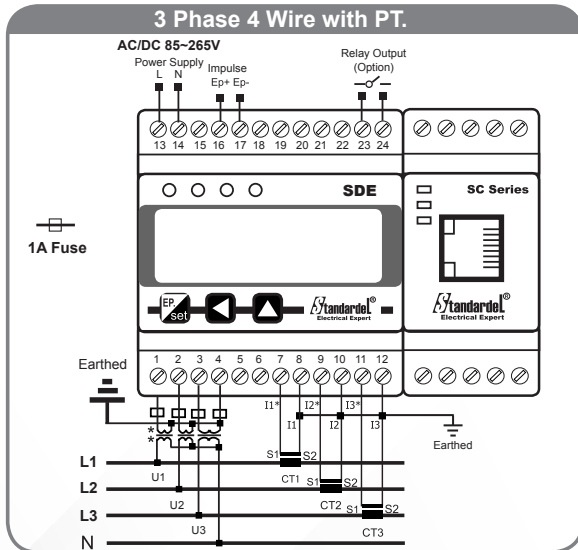
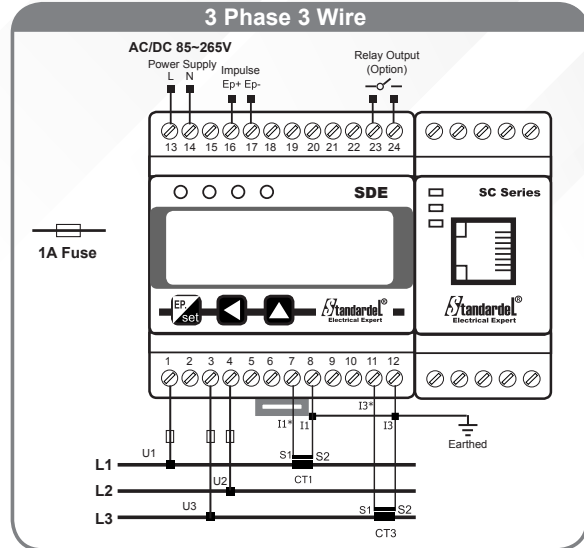
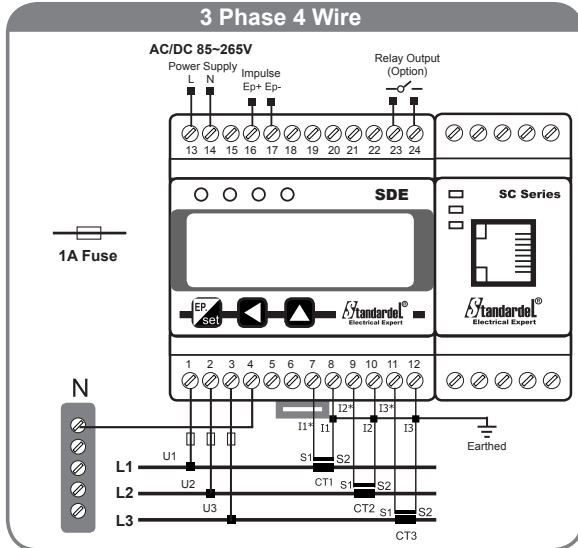

#### 1. Voltage Input:

- (1) When line-line voltage is more than rating 500V, it's best to use PT;
- (2) For safe wiring and lightning protection, best to wire the 1A fuse on voltage inputs and power supply L line;

#### 2. Current Input:

- (1) When current is more than rating 5A, it's best to use CT;
- (2) If there is other kWh meter or ammeter on the AC line, please mount SDE400E in series connection with their current transformers;
- (3) Before disconnect current input, make sure disconnect CT primary circuit or short CT secondary circuit;
- (4) Make attention of current transformer direction, including installation direction P1,P2 and wiring direction S1,S2; The reverse current will cause negative active power and negative energy value;

3. Make sure that **each phase current matches its voltage**, including their phase number and their direction; otherwise it will cause error measuring or error sign;

4. The normal SDE430E need **auxiliary power supply**, its work voltage is AC/DC85-265V (sometimes we get the its auxiliary power from one phase voltage input);

## 5.2 SDE430E-C ( WITH 3 SPLIT CORE CT. ) SDE430E-R ( WITH 3 ROGOWSKI COIL )

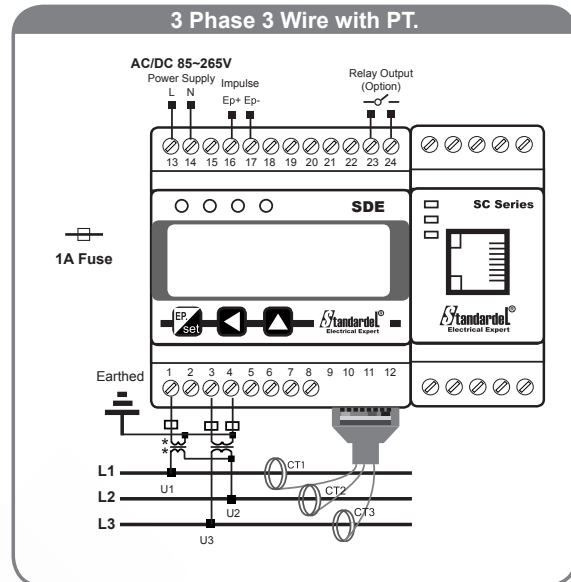
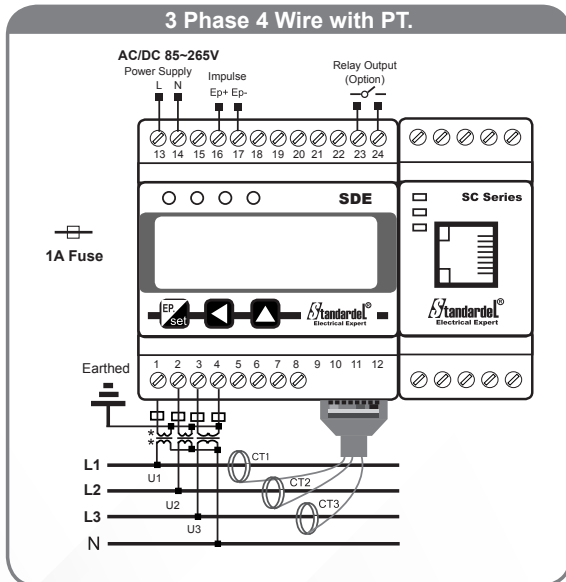
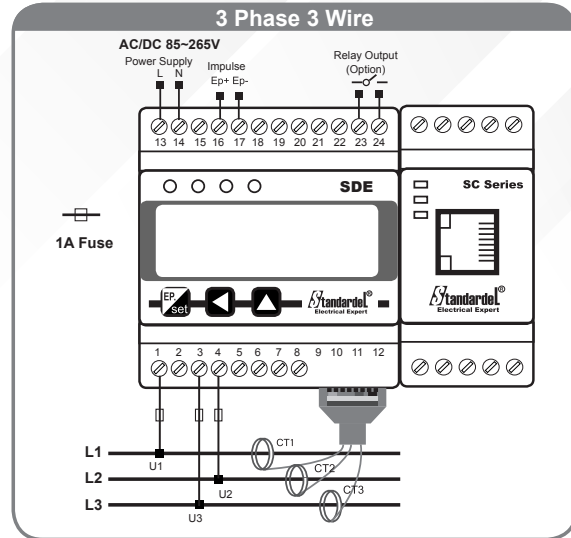
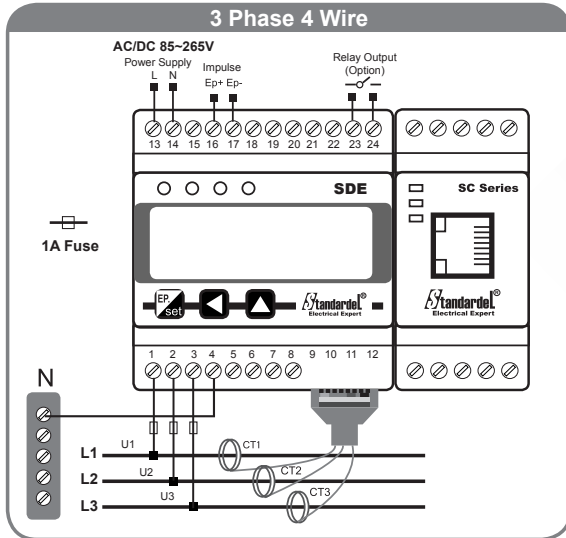

### 1. Voltage Input:

- (1) When line-line voltage is more than rating 500V, it's best to use PT;
- (2) For safe wiring and lightning protection, best to wire the 1A fuse on voltage inputs and power supply L line;

### 2. Current Input:

- (1) Each SDE430E-C/R must be installed with its own 3 split core CTs (or rogowski coils), its has the **same serial number with its own split core CTs (or rogowski coils)**;
- (2) Each split core CT (or rogowski coil) has the **own color for different phase** (yellow-L1, green-L2, red-L3);
- (3) There is an **arrow sticker** on each split core CT (or rogowski coil), and its direction must be **same as current direction**, otherwise it will cause negative active power and energy value;
- (4) split core CT and rogowski coil are special sensor of AC current, **it doesn't need to connect with earth**;

**3. Make sure that each phase current matches its voltage**, including their phase number and their direction; otherwise it will cause error measuring or error sign;

**4. The normal SDE430E need auxiliary power supply**, its work voltage is AC/DC85-265V (sometimes we get the its auxiliary power from one phase voltage input);

## 6. DISPLAY

### Display Pages

**Energies**

Import active energy <b>123456.78</b> kWh	Export active energy <b>-000006.78</b> kWh	Inductive reactive energy <b>002346.78</b> kVarh	Capacitive reactive energy <b>-000456.78</b> kVarh
--	---	---	---

◀

**Parameters**

Product Model <b>SDE430E</b>	Modbus Slave Address <b>Addr 030</b>	Baud rate <b>bAud9.600</b>	Data Format <b>dAtA n.8.1</b>
PT Ratio <b>Pt 0.100</b>	CT Ratio <b>Ct 0050</b>	Pulse constant <b>6400</b>	Wiring Error Code <b>AL - 010</b>

◀

**Electrical Values**

Voltage of Phase L1 <b>U<sub>A</sub> 219.9</b> V	Voltage of Phase L2 <b>U<sub>B</sub> 220.0</b> V	Voltage of Phase L3 <b>U<sub>C</sub> 220.0</b> V
Voltage of Phase L1&L2 <b>U<sub>AB</sub> 219.9</b> V	Voltage of Phase L2&L3 <b>U<sub>BC</sub> 220.0</b> V	Voltage of Phase L3&L1 <b>U<sub>AC</sub> 220.0</b> V

While 3P3L, only displays line voltages

Current of Phase L1 <b>i<sub>A</sub> 30.000</b> A	Current of Phase L2 <b>i<sub>B</sub> 29.999</b> A	Current of Phase L3 <b>i<sub>C</sub> 30.001</b> A
--	--	--

◀

Total Active Power <b>P<sub>Σ</sub> 9.90</b> kW	Active Power L1 <b>P<sub>A</sub> 3.30</b> kW	Active Power L2 <b>P<sub>B</sub> 3.30</b> kW	Active Power L3 <b>P<sub>C</sub> 3.30</b> kW
Total Reactive Power <b>Q<sub>Σ</sub> 9.90</b> kvar	Reactive Power L1 <b>Q<sub>A</sub> 3.30</b> kvar	Reactive Power L2 <b>Q<sub>B</sub> 3.30</b> kvar	Reactive Power L3 <b>Q<sub>C</sub> 3.30</b> kvar
Total Apparent Power <b>S<sub>Σ</sub> 19.80</b> kVA	Apparent Power L1 <b>S<sub>A</sub> 6.60</b> kVA	Apparent Power L2 <b>S<sub>B</sub> 6.60</b> kVA	Apparent Power L3 <b>S<sub>C</sub> 6.60</b> kVA
Total Power Factor <b>PF<sub>Σ</sub> 0.500</b>	Power Factor L1 <b>PF<sub>A</sub> 0.500</b>	Power Factor L2 <b>PF<sub>B</sub> 0.500</b>	Power Factor L3 <b>PF<sub>C</sub> 0.500</b>

While 3P3L, there isn't power value of each phase

◀

Frequency <b>F 50.00</b> Hz
--------------------------------

**Note:**





























































- SDE430E can display main 27 parameters, the user may change display page by button;
- After set PT or CT ratio, SDE400E displays real values; you don't need multiply the PT or CT ratio again;
- SDE430E-C/R doesn't need to set CT ratio, because it reads the real values on bus;
- You may check SDE400E/430 parameters without into setting menu;
- [AL] wiring error code: with 3 digits.

	X	X	X
Normal	0 – Normal	0 – Normal	0 – Normal
Error	1 – phase sequence error	1 – reversed current	1 – lose phase voltage
Reason	There is unmatch of phase current and phase voltage	There is split core CT mounted reversedly	There is missing of phase voltage



## 7. PROGRAMMING

### 7.1 BUTTON SETTING LOCALLY

Programming Menu				
	<p><b>Enter programming password</b></p> <p>1. Under reading pages, press and keep  4 seconds to go into Programming mode;            2. Default enter programming password is 0000;            3. Press   to choose digit, Press  to confirm password.</p>			
	<p><b>Choose Network:</b></p> <p>- 3P4L            - 3P3L</p> <p>Press   to change value;</p>	<td></td> <td> <p><b>Set RS485 Baud rate:</b></p> <p>1.Option value: -1.200(1200bps)            -2.400(2400bps) -4.800(4800bps)            -9.600(9600bps) -19.20(19200bps)            -38.40(38400bps)</p> <p>2.Press   to change value;</p> </td>		<p><b>Set RS485 Baud rate:</b></p> <p>1.Option value: -1.200(1200bps)            -2.400(2400bps) -4.800(4800bps)            -9.600(9600bps) -19.20(19200bps)            -38.40(38400bps)</p> <p>2.Press   to change value;</p>
	<p><b>Set PT Ratio:</b></p> <p>1.Option value: 0001- 9999            2.Press   to change value;            (4000/400V, set PT = 10)</p>	<td></td> <td> <p><b>Set RS485 frame mode:</b></p> <p>1.Option value:            - n,8,1 (1 stop bit, no parity)            - o,8,1 (1 stop bit,odd parity )            - e,8,1 (1 stop bit,even parity)            - n,8,2 (2 stop bit,no parity)</p> <p>2.Press   to change value;</p> </td>		<p><b>Set RS485 frame mode:</b></p> <p>1.Option value:            - n,8,1 (1 stop bit, no parity)            - o,8,1 (1 stop bit,odd parity )            - e,8,1 (1 stop bit,even parity)            - n,8,2 (2 stop bit,no parity)</p> <p>2.Press   to change value;</p>
	<p><b>Set CT Ratio:</b></p> <p>1.Option value: 0001- 9999            2.Press   to change value;            (200/5A, set CT= 40)</p>	<td></td> <td> <p><b>Reset all energies' value:</b></p> <p>1.Option value: - no - yes            2.Press   to change value;            (Attention: After reset energy values, they can be recovered)</p> </td>		<p><b>Reset all energies' value:</b></p> <p>1.Option value: - no - yes            2.Press   to change value;            (Attention: After reset energy values, they can be recovered)</p>
	<p><b>Choose Protocol:</b></p> <p>- mod (Modbus-RTU)            - 645 (DL/T645)</p> <p>Press   to change value;</p>	<td></td> <td> <p><b>Set LCD backlight duration:</b></p> <p>1.Option value: 0-255 (seconds)            2.Press   to change value;            (value 0: backlight is always ON;            default value is 60 seconds)</p> </td>		<p><b>Set LCD backlight duration:</b></p> <p>1.Option value: 0-255 (seconds)            2.Press   to change value;            (value 0: backlight is always ON;            default value is 60 seconds)</p>
	<p><b>Set Modbus Slave Address:</b></p> <p>1.Option value: 1- 247            2.Press   to change value;</p>	<td></td> <td> <p><b>Set programming password:</b></p> <p>1.Option value: 0-9999 (Default 0000)            2.Press   to change value;</p> </td>		<p><b>Set programming password:</b></p> <p>1.Option value: 0-9999 (Default 0000)            2.Press   to change value;</p>
		<td></td> <td> <p><b>Save programming values:</b></p> <p>1.press &amp; keep  3sec to enter Save Page;            2.Option value: - no - yes            3.Press   to choose;Press  to confirm saving.</p> </td>		<p><b>Save programming values:</b></p> <p>1.press &amp; keep  3sec to enter Save Page;            2.Option value: - no - yes            3.Press   to choose;Press  to confirm saving.</p>

#### Attention:

1. SDE400E/430 is cabled on 3P4W or 3P3W, then set network on it;
2. SDE430E's CT ratio is fixed under production, no need to change;
3. After setting, have to save the setting;

To check the good setting on the parameter menu, after setting



## 7.2 SOFTWARE SETTING REMOTELY BY RS485

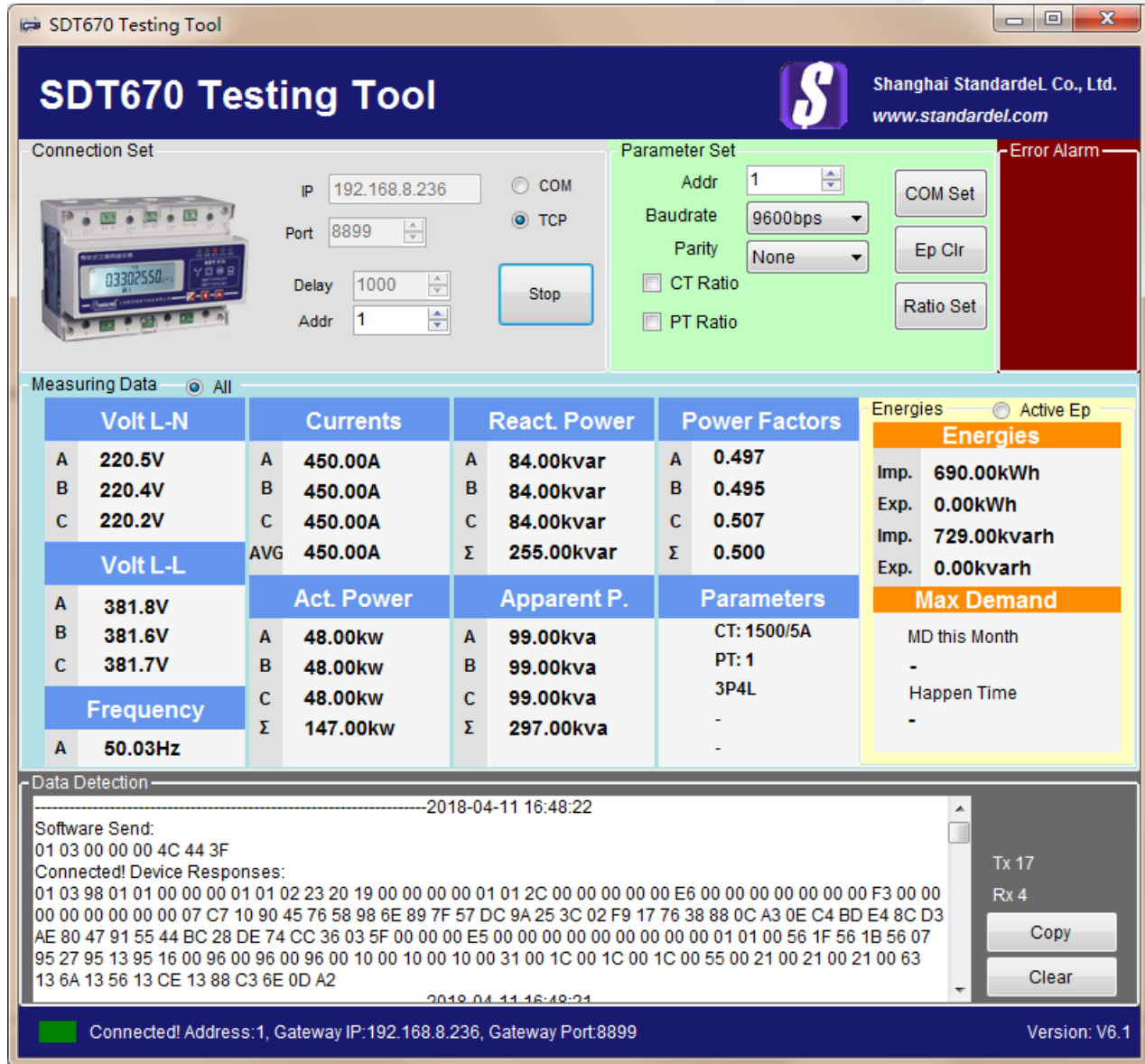

**SDT670 Testing Tool** Shanghai Standardel Co., Ltd. [www.standardel.com](http://www.standardel.com)

**Connection Set**

IP: 192.168.8.236    Port: 8899    Delay: 1000    Addr: 1

COM    TCP

Stop

**Parameter Set**

Addr: 1    Baudrate: 9600bps    Parity: None

CT Ratio    PT Ratio

COM Set    Ep Clr    Ratio Set

**Measuring Data** All

Volt L-N		Currents		React. Power		Power Factors	
A	220.5V	A	450.00A	A	84.00kvar	A	0.497
B	220.4V	B	450.00A	B	84.00kvar	B	0.495
C	220.2V	C	450.00A	C	84.00kvar	C	0.507
AVG		450.00A		Σ 255.00kvar		Σ 0.500	
Volt L-L		Act. Power		Apparent P.		Parameters	
A	381.8V	A	48.00kw	A	99.00kva	CT: 1500/5A	
B	381.6V	B	48.00kw	B	99.00kva	PT: 1	
C	381.7V	C	48.00kw	C	99.00kva	3P4L	
Σ		147.00kw		Σ 297.00kva			
Frequency							
A	50.03Hz						

**Energies** Active Ep

**Energies**

Imp. 690.00kWh  
Exp. 0.00kWh  
Imp. 729.00kvarh  
Exp. 0.00kvarh

**Max Demand**

MD this Month  
-  
Happen Time  
-

**Data Detection**

2018-04-11 16:48:22

Software Send:  
01 03 00 00 00 4C 44 3F

Connected! Device Responses:  
01 03 98 01 01 00 00 00 01 01 02 23 20 19 00 00 00 00 01 01 2C 00 00 00 00 00 E6 00 00 00 00 00 00 F3 00 00  
00 00 00 00 00 00 07 C7 10 90 45 76 58 98 6E 89 7F 57 DC 9A 25 3C 02 F9 17 76 38 88 0C A3 0E C4 BD E4 8C D3  
AE 80 47 91 55 44 BC 28 DE 74 CC 36 03 5F 00 00 00 E5 00 00 00 00 00 00 00 00 01 01 00 56 1F 56 1B 56 07  
95 27 95 13 95 16 00 96 00 96 00 96 00 10 00 10 00 10 00 31 00 1C 00 1C 00 1C 00 55 00 21 00 21 00 21 00 63  
13 6A 13 56 13 CE 13 88 C3 6E 0D A2

2018-04-11 16:48:21

Connected! Address:1, Gateway IP:192.168.8.236, Gateway Port:8899    Version: V6.1

### – Software function:

SDT670\_Testing Tool can

1. To test the RS485 communication quality;
2. To read all the measuring data of SDE400E
3. To make mass setting of SDE400E's Modbus slave address and baudrate.;
- 3) To clear SDE430E's energies data.

### – Operation Step:

**Step1:** Run "SDT670\_Test.exe".

**Step2:** choose correct serial port, baudrate, parity on PC, input SDE400E slave address (Def. 01); then click [Read] button to begin reading SDE400E's data. (Def. read one time 1 seconday)

(if the left bottom displays , software is well connected with SDE400E, and all the measuring data are in their corresponding text box.)

(if the left bottom displays , software doesn't connect with SDE400E, please check the error reason after .)

**Step3:** If you well read the data of SDE430E, the button [COM Set] [Ep Clr] [Ratio Set] will be activated:

- to click [Ep Clr] to reset all the energies' value to zero;
- after inputing the slave adress or baudrate or parity, to click [COM Set] to change SDE400E's RS485 parameters;
- after inputing the CT or PT ratio, to click [Ratio Set] to change wiring parameters.

## 8.MODBUS PROTOCOL

### 8.1 REGISTER MAP

Register Code Dec	Register Code Hex	Items	Format	Read Write	Explanation
0 - high	00 - high	Slave Address	UInt8	R/W	Range: 001~247 (Default 001)
- low	- low	Baud rate	UInt8	R/W	1:9600bps (Default: 1) 2:4800bps 3:2400bps 4:1200bps 5:19200bps 6:38400bps
1 - high	01 - high	Data Frame format	UInt8	R/W	0: 8,n,1 (Default:0) 1: 8,e,1 2: 8,o,1 3: 8,n,2
- low	- low	Line Mode	UInt8	R	0:3P4L; 1:3P3L (Default: 0)
2~5	02~05	Empty			
6 - high	06 - high	Error Alarm Message	UInt8	R	0000 0 0 0 0 (0-No; 1-Alarm) Er Phases UL3 UL2 UL1
- low	- low	Current sense	UInt8	R	00000 0 0 0 (0 postive; 1 negative) IL3 IL2 IL1
7	07	PT ratio	UInt16	R/W	0001~9999 (External PT 10kV/100V, ratio = 100)
8	08	CT ratio	UInt16	R/W	0001~9999 (External CT 200/5A, ratio = 40)
9 - high	09-high	Control Relay (Option)	UInt16	R/W	0:Open Relay; 1:Close Relay
- low	- low	Relay State (Option)	UInt16	R	0:Open; 1:Close
10,11	0A,0B	Import active energy	UInt32	R/W	RealValue = (65536*Registor_H+Registor_L)/100 (Unite: kWh)
12,13	0C,0D	Export active energy	UInt32	R/W	
14,15	0E,0F	Inductive reactive energy	UInt32	R/W	RealValue = (65536*Registor_H+Registor_L)/100 (Unite: kVarh)
16,17	10,11	Capacitive reactive energy	UInt32	R/W	
18~49	12~31	Empty			
50	32	Voltage L1-N	UInt16	R	RealValue = RegistorValue/100 (Unit: V)
51	33	Voltage L2-N	UInt16	R	
52	34	Voltage L3-N	UInt16	R	
53	35	Voltage between L1 & L2	UInt16	R	
54	36	Voltage between L2 & L3	UInt16	R	
55	37	Voltage between L3 & L1	UInt16	R	RealValue = RegistorValue/100 (Unite: A)
56	38	Current on phase L1	UInt16	R	
57	39	Current on phase L2	UInt16	R	
58	3A	Current on phase L3	UInt16	R	RealValue = RegistorValue/100 (Unite: kW)
59	3B	Active power on phase L1	UInt16	R	
60	3C	Active power on phase L2	UInt16	R	
61	3D	Active power on phase L3	UInt16	R	
62	3E	Total Active power	UInt16	R	

63	3F	Reactive power phase L1	UInt16	R	RealValue = RegistorValue/100 (Unite: kVar)
64	40	Reactive power phase L2	UInt16	R	
65	41	Reactive power phase L3	UInt16	R	
66	42	Total Reactive power	UInt16	R	
67	43	Apparent power phase L1	UInt16	R	RealValue = RegistorValue/100 (Unite: kVA)
68	44	Apparent power phase L2	UInt16	R	
69	45	Apparent power phase L3	UInt16	R	
70	46	Total Apparent power	UInt16	R	
71	47	Power factor on phase L1	UInt16	R	RealValue = RegistorValue/10000
72	48	Power factor on phase L2	UInt16	R	
73	49	Power factor on phase L3	UInt16	R	
74	4A	Total Power factor	UInt16	R	
75	4B	Frequency	UInt16	R	RealValue = RegistorValue/1000 (Unite: Hz)

1. Data Format: One registor with 2 bytes, hight byte before, low byte behind

UInt8: 8bits unsigned integer;

UInt16: 16 bits unsigned integer;

UInt32: 32bits unsigned integer;

Int16: 16 bits signed integer;

2. The registor values are secondary values, and they needs to multiply CT&PT ratio to get real values.

For SDE400E and SDE430E-C5, their CT ratio is set according to external CT;

For SDE430E-C, their CT ratio is 1 and can't be change;

For SDE430E-R, their CT ratio is 5 and can't be change;



## 8.2 INTERFACE

1. SDE400E/430 is equipped with 2-cables half-duplex RS485 interface and it is built-in standard Modbus-RTU protocol; the cables should be Shielded Twisted Pair and its diameter should above 0.5 mm<sup>2</sup>.
2. On one RS485 line, there are able to connect maximan 32 devices; every SDE430E must have own different slave address.
3. The wiring of RS485 cables should be far away HV cables or HV environment; we suggest wiring of Mode T, not Mode Star
4. Programmable Baudrate 9600, 4800, 2400, 1200bps, 19200bps, 38400bps  
default is 9600bps
5. Data Transmit Format: 1 start bit, 8 data bit, 1 stop bit, no parity

## 8.3 PROTOCOL

Modbus-RTU: it is the communication mode between master device and slave device on one RS485 line. At first, the master device requests one sole slave device; then this slave device reponses master device

Modbus-RTU allow to commnunicate only between master device and slave device and don't allow to communiatue among slave devices. Therefore the slave devices don't occupy the communication line when it initialize.

Master request: request frame includes slave address, function code, data and CRC check.

Slave Address	Function Code	Data	CRC16 Check
1 byte	1 byte	N bytes	2 bytes

Slave Address: every analyzer has one address different from others on one RS485 line; range from 1~247; only requested analyzer will response master.

Function Code:

Hex order	Function
03H	Read data from one or several register(s)
10H	Write data into one or several register(s)

Data: including read or write data

CRC16 check:  $x^{16} + x^{15} + x^2 + 1$

## 8.4 EXAMPLE

1. Read registers: want to read the currents of 3 phases of analyzer's slave address 01.

Master request:

Slave Address	Function	Start Register	Register Number	CRC
01H	03H	00H,38H	00H,03H	84H,06H

SDE430E response:

Slave Address	Function	Byte Number	Data	CRC
01H	03H	06H	27H,27H,27H,11H,27H,0AH	D2H,E3H

AL1 = (27Hx100H+27H)/100 = 100.23A

AL2 = (27Hx100H+11H)/100 = 100.01A

AL3 = (27Hx100H+0AH)/100 = 99.94A

2. Read registers: want to read the import reactive energy of analyzer's slave address 10.

Master request:

Slave Address	Function	Start Register	Register Number	CRC
0AH	03H	00H,50H	00H,02H	C5H,61H

SDE430E response:

Slave Address	Function	Byte Number	Data	CRC
0AH	03H	04H	01H,02H,03H,04H	E1H,FCH

Import kVarh = (10000Hx(100Hx01H+02H) + (100Hx03H+04H))/100 = 169090.00 kVarh

## **10. FEEDBACK**

### **1. SDE400E/430 doesn't work**

*SDE400E/430 needs auxiliary power supply to work, and work voltage is AC/DC85~265V. To check its power supply voltage on its connector 13,14.*

### **2. Electrical value error**

*2.1. Please make sure of correct wiring of input current and of input voltage to SDE400E/430, after wiring, you may use multimeter to check whether the input values are correct;*

*2.2. Please make sure of phase sequence is correct, it means that L1 current input must be matched to L1 voltage input;*

*2.3. The measured values by SDE400E/430 are RMS, they are a little different from the measured values by multimeter. It is normal;*

*2.4 If there is external CT. please check whether it is set CT. ratio;*

### **3. Energy value error**

*3.1 SDE400E/430's accumulated energy values are based on active power values, if energy values aren't correct, please check whether active power values and PF values are corresponding to real values.*

*3.2 SDE400E/430 counts bidirectional active energies, if the current wiring or CT secondary wiring is inverse, the active energy will be counted on export active energy. So you have to make current wiring again.*

### **4. SDE400E/430 Err Alarms LED (Please check the error code on display menu)**

*1. There is no current or no voltage on any one of 3 phase;*

*2. Any current input doesn't match its voltage input;*

*3. On 3P3L wiring, Err Alarm LED will turn on;*

*4. To measure the unbalance 3 phases load, Err Alarm LED will turn on.*